

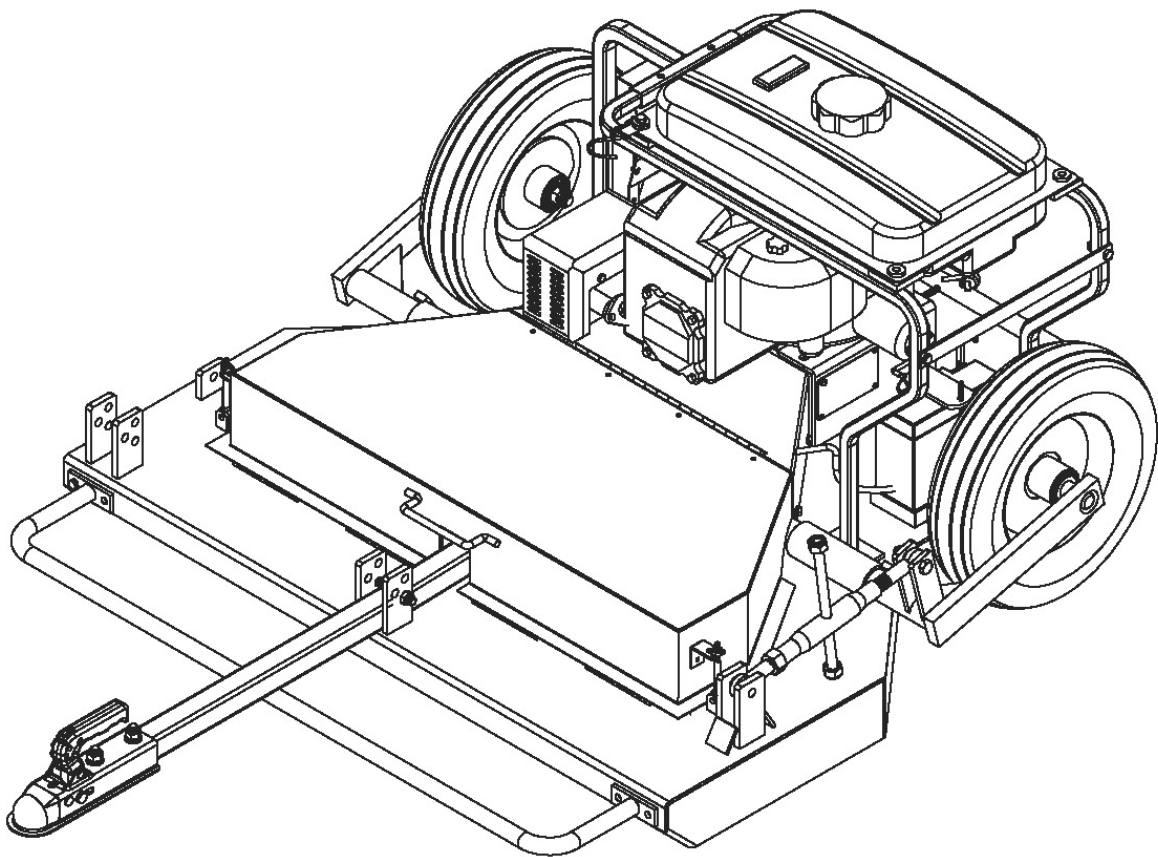

SHARK

LAWN MOWER 117 cm



REV051718 NG04

Instruction & Assembly

SAVE THESE INSTRUCTIONS FOR FUTURE REFERENCE

Official Distributor:



ASP Group s.r.o.

Staroplzenecka 290, Letkov, 326 00, Czech Rep.

+420 378 21 21 21 / info@aspgroup.cz

Table of Contents

| | |
|---|--|
| General Warnings and Rules | 3 |
| Hazard Signal Word Definitions..... | 4 |
| Controls and Features Identification..... | 5 |
| Assembly Instructions | 6, 7, 8 |
| Operation Instructions | 9, 10, 11, 12, 13 |
| Maintenance and Storage | 14 |
| Specification..... | 15 |
| Parts Drawing & Parts List | 16, 17, 18, 19, 20, 21, 22, 23, 24, 25, 26, 27 |

GENERAL WARNINGS

READ and UNDERSTAND this manual completely before using the Heavy Duty Mulch Mower. Operator must read and understand all safety and warning information, operating instructions, maintenance and storage instructions before operating this equipment. Failure to properly operate and maintain the mower could result in serious injury to the operator or bystanders.

Operation Warnings

- Do not at any time carry passengers, sit or stand on the mower.
- Do not allow children to play on, stand upon or climb on the mower.
- Always inspect the mower before using to assure it is in good working condition.
- Replace or repair damaged or worn parts immediately.
- Always check and tighten hardware and assembled parts before operation.
- Always keep hands and feet clear from discharge area and blades.
- Keep safety devices, guards and deflectors in place when operating.
- Avoid large holes and ditches when towing and operating the equipment.
- Always operate the mower on clear and level ground.
- Always operate at reduce speed in rough terrain, along creeks, ditches and on hillsides.
- Do not operate close to creeks, ditches and public highways.
- Only operate with recommended vehicles (Lawn/Garden Tractors and ATVs).
- To avoid personal injury and/or equipment damage **DO NOT EXCEED 8 KPH.**
- Always refer to the vehicle owner's manual for proper towing.
- Always secure and lock the mower to the tow vehicle before operating.

Crush and Cut Hazards

- Always keep hands and feet clear from blades and moving parts while operating the equipment.
- Always clear and keep work area clean and free of debris when operating.
- Always wear safety gear, eye & ear protection, gloves and work boots when operating the mower.





WARNING

The warnings, cautions, and instructions outlined in this instruction manual cannot cover all possible conditions or situations that may occur. It must be understood by the operator that common sense and caution are factors which cannot be built into this product and must be supplied by the operator.

Assembly Is Required

This product requires assembly before use. See "Assembly" section for instructions. Because of the weight and/or size of the mower, it is recommended that another adult be present to assist with the assembly. **INSPECT ALL COMPONENTS** closely upon receipt to make sure no components are missing or damaged.

Hazard Signal Word Definitions

| | |
|---|---|
|  | <p>This is the safety alert symbol. It is used to alert you to potential personal injury hazards. Obey all safety messages that follow this symbol to avoid possible injury or death.</p> |
|  | <p>DANGER indicates an imminently hazardous situation which, if not avoided, will result in death or serious injury.</p> |
|  | <p>WARNING indicates a potentially hazardous situation which, if not avoided, could result in death or serious injury.</p> |
|  | <p>CAUTION indicates a potentially hazardous situation which, if not avoided, may result in minor or moderate injury.</p> |
|  | <p>CAUTION used without the safety alert symbol indicates a potentially hazardous situation which, if not avoided, may result in property damage.</p> |

ABOUT YOUR HEAVY DUTY MULCH MOWER

This mulch mower is designed to get the job done right and produce a quality finish cut. It features a 117cm cutting width, electric start and is powered by a robust 16hp engine. Your mulch mower should be operated behind lawn/garden tractors, ATV, golf cart or other approved vehicles. Never exceed maximum operating speed of 8 KPH.

Technical specifications on the mower are provided in the “Specifications” section of this manual.

Controls and Features Identification

Read this owner's manual before operating the equipment. Familiarize yourself with the location and function of the controls and features. Save this manual for future reference.

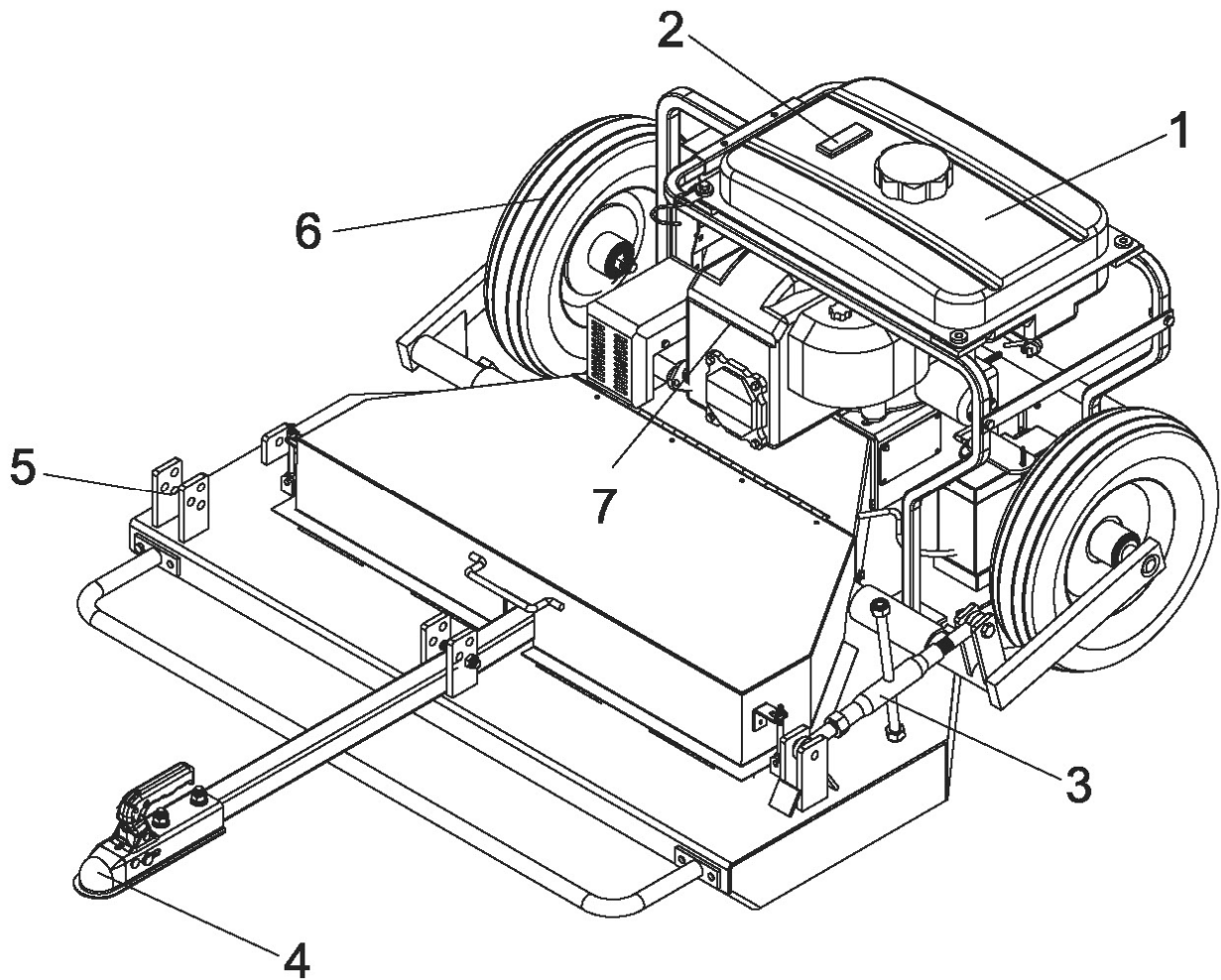

- 1) **Fuel Tank** – Holds 13L.
- 2) **Fuel Gauge** – Monitors fuel level.
- 3) **Blade Handle Adjustment** – Adjust blade height.
- 4) **Hitch Coupler** – Attaches to towing vehicle.
- 5) **Offset Bracket** – Allows mower to be offset.
- 6) **Tires** - Maximum rated 206 KPa / 30 PSI.
- 7) **Engine** – 16hp vertical air cooled.



CAUTION

Read and follow all instructions for assembly and operation. Failure to properly assemble this equipment could result in serious injury to the user or bystanders, or cause equipment damage.

HEAVY DUTY MULCH MOWER ASSEMBLY

Set the shipping crate on a solid flat surface and carefully remove the lid. Use two people and take all parts out of the shipping crate and inspect the components to ensure there are no missing pieces before starting to assemble the mower follow steps 1 through 5.

TOOLS REQUIRED

- Rubber or Wooden Hammer
- 13mm, 14mm, 17mm, 19mm Wrenches

Assembly Instructions

STEP 1: Fuel Tank and Support Frame Assembly

1. Connect the three support frames together (#49, #51 & #47) using two M8x35 hex bolts (#53) and M8 lock nuts (#4).
2. Attach the fuel tank (#48) to the corners of the support frame using three M8x25 hex bolts (#2), Ø 8 lock washers (#3) and Ø8 big washers (#52). The fourth corner using a M8x25 hex bolts (#2), Ø 8 lock washers (#3), Ø8 big washers (#52) and a hook (#132).
3. Fix connect bar (#50) to the support frame (A to A) using two M8x35 hex bolts (#53) and M8 lock nuts (#4).

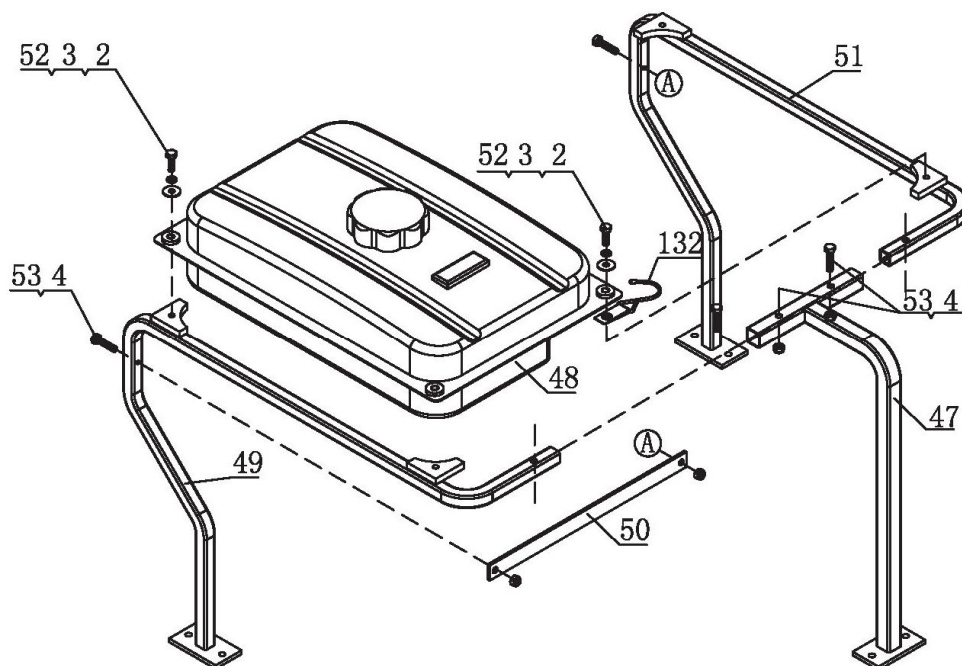

STEP 2: Attach Tow Bar and Safety Rod to Mower Base

1. Attach tow bar (#21) to the mower base using two M12x80 hex bolts (#26) and M12 lock nuts (#27).
2. Attach safety rod front (#19) to the mower base using four M10X25 hex bolts (#16), Ø 10 lock washers (#17) and M10 nylon lock nuts (#18).
3. Attach safety rod back (#44) to the mower base using four M10X25 hex bolts (#16), Ø 10 lock washers (#17) and M10 nylon lock nuts (#18).

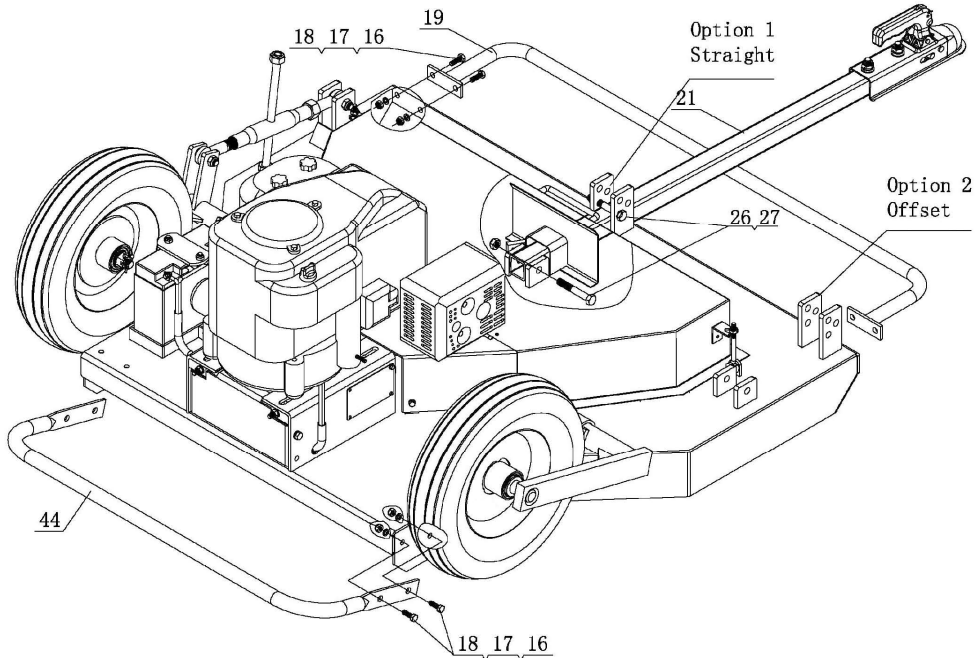

Note: Two locations for attaching the tow bar depending on application.

Step 3: Attach Fuel Tank Assembly to Mower Base

1. Place fuel tank assembly over the holes on the mower base (#20) and secure with six M8x25 hex bolts (#2), Ø8 lock washers (#3) and M8 lock nuts (#4).

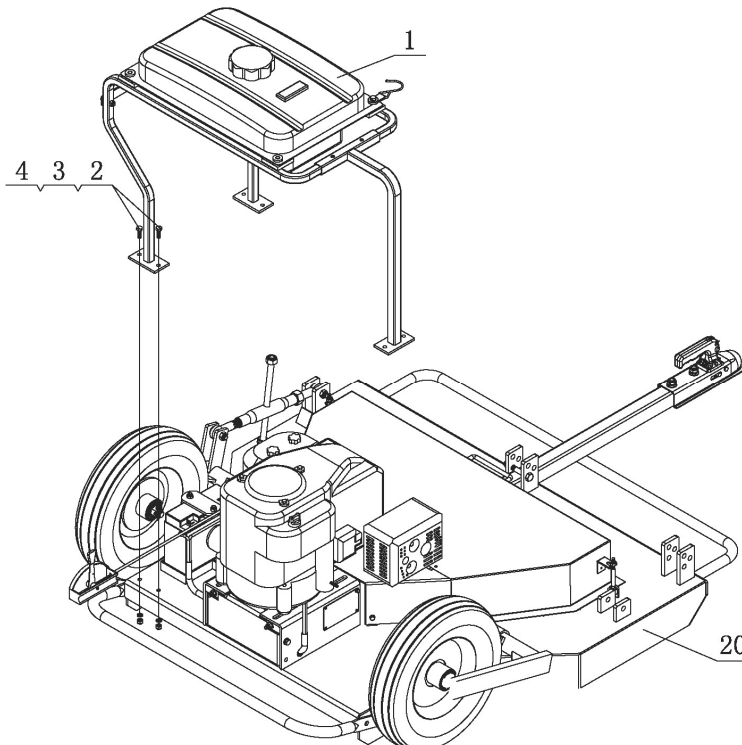

**Engine Shipped Without Oil.**

Before starting engine, fill with motor oil.
See engine manual for engine oil type and capacity.

STEP 4: Add Engine Oil

1. Make sure the mower is on a level surface.
2. Remove oil fill cap/dipstick to add oil.
3. Refer to the separate owner's engine manual for the amount of engine oil needed; replace oil fill cap/dipstick.
4. Check engine oil level daily and add as needed.

NOTE: During the break-in period check the engine oil level often.

**CAUTION**

DO NOT attempt to crank or start the engine before it has been properly filled with the recommended type and amount of oil. Damage to the mower engine as a result of failure to follow these instructions will void your warranty.

STEP 5: Add Gasoline to Fuel Tank

1. Use only clean, fresh, regular unleaded fuel with a minimum 85 octane rating.
2. DO NOT mix oil with fuel.
3. Remove the fuel cap and slowly add fuel to the tank. DO NOT overfill allow approximately .64cm of space for fuel expansion.
4. Screw on the fuel cap and wipe away any spilled fuel.

**DANGER**

Mower engine exhaust contains carbon monoxide, a colorless, odorless, poison gas. Breathing carbon monoxide will cause nausea, dizziness, fainting or death. If you start to feel dizzy or weak, get to fresh air immediately.

Operate mower outdoors only in a well ventilated area.

DO NOT operate the mower inside any building, enclosure or compartment.

DO NOT allow exhaust fumes to enter a confined area through windows, doors, vents or other openings.

DANGER CARBON MONOXIDE, using a mower indoors **CAN KILL YOU IN MINUTES.**

**CAUTION**

Fuel and fuel vapors are highly flammable and extremely explosive.

Fire or explosion can cause severe burns or death.

Unintentional startup can result in entanglement, traumatic amputation or laceration.

Only use regular unleaded gasoline with a minimum 85 octane rating.

DO NOT mix oil and gasoline together.

Fill tank approximately .64cm below the top of the tank to allow for fuel expansion.

DO NOT fill fuel tank indoors or when the engine is running or hot.

DO NOT light cigarettes or smoke when filling the fuel tank.

Operation Instructions

WARNING

Before operating or using the mower, review the instructions below and all safety information. Failure to follow these instructions may result in property damage or injury to the operator or bystanders.

USING YOUR MULCH MOWER

1. **ONLY** adults familiar with these instructions should operate this equipment. Never allow children to operate this equipment.
2. **NEVER** use your mower with other people or children in close proximity.
3. **ONLY** tow the mower with recommended vehicles (Lawn/Garden Tractors and ATVs).
4. **KEEP** hands and feet clear of rotating blades, pulleys, belts and discharge openings when operating the mower.
5. **DO NOT** operate mower with barefoot or wearing open toe sandals always wear a solid shoe with good traction.
6. **DO NOT** operate equipment while under the influence of alcohol or drugs.
7. **ALWAYS** disconnect the spark plug wire to prevent accidental starting of the engine when setting up, transporting, adjusting or making repairs.
8. **NEVER** make any adjustments to your mower while the engine is running.
9. **ALWAYS** turn the engine off when not mowing or when the equipment is unattended.
10. **ALWAYS** check all hardware to make sure they are tight after the first hour of running to ensure trouble free service.
11. **ALWAYS** keep safety devices, guards and deflectors in place when operating.
12. **NEVER** mow in reverse. Always look down and behind before and while backing up the mower.
13. **ALWAYS** stop and inspect the equipment if you strike an object. Repair if necessary before operating again.
14. **ALWAYS** clear work area of objects (rocks, toys, wire & etc) before operating the mower.
15. **DO NOT** operate mower if it has been dropped or damaged or if the mower vibrates excessively. Excessive vibration is an indication of damage.
16. **ALWAYS** avoid sudden turns, changes in direction and speed.
17. **DO NOT** exceed the maximum operating speed of 8 KPH.
18. **ALWAYS** operate mower engine at full throttle for best cutting results and maximum material discharge.
19. **ALWAYS** allow wet grass to dry. Wet grass will clump and collect under the mowing deck.
20. **ALWAYS** operate at slower speeds in high or dense grass areas. Some areas may need to be mowed twice.
21. Creating a manicured lawn never cut more than 1/3 of the grass height in one cutting.

WARNING

Tragic accidents may occur if the operator is not alert to the presence of children. Children are often attracted to mowing activities. Never assume that children will remain where you saw them last.

When operating the mower it produces foreign objects that can be thrown into the eyes. Always wear certified safety glasses before operating the equipment.

The operation of mowing produces sound waves that may damage the human ear. Ear protection is highly recommended when operating this equipment.

Operation Instructions

Attaching Mulch Mower to Tow Vehicle

1. Make sure blades are not blocked with grass or other matter.
2. Check all electrical connections for build up or debris before operating.
3. Check the tires to make sure they have the proper amount of air.

TIRE WARNING

DO NOT over inflate tires or use if worn or will not hold air. Serious injury can result if tires explode while operating the mower.
DO NOT exceed the maximum operating speed 8 KPH.

4. Check engine oil level before starting.
5. Determine which towing option is needed, option 1 (straight) or option 2 (offset) works best for your vehicle.

NOTE: Use option 2 to offset the mower to opposite side of the tow vehicle discharge (if any). This prevents the tow vehicle from throwing grass into mulch mower engine.

6. Adjust blade height (See blade height adjustment section).
7. Refer to the vehicle owner's manual for proper towing.
8. Back vehicle up to the desired towing position.
9. Attach the tow hitch to the vehicle. Always secure and lock the mower to the vehicle before operating.

TOWING WARNING

Serious injury or death can occur if towing safety rules are not followed.
Always secure and lock the mower to the vehicle hitch before moving.
Drive safely. Be aware of the added length of the mower.
Never exceed the maximum operating speed of 8 KPH.
Never ride or transport cargo on the mower.
Turn off the vehicle and mower engine before leaving the mower unattended.

Operation Instructions

Blade Height Adjustment

1. Mower engine needs to be turned off before adjusting the blade height.
2. Blade height is adjusted by turning the handle clockwise to lower the blades and counterclockwise to raise the blades.
3. Make sure the mower deck is kept horizontal at all times by adjusting the draw bar.

NOTE: *The draw bar can be offset.*

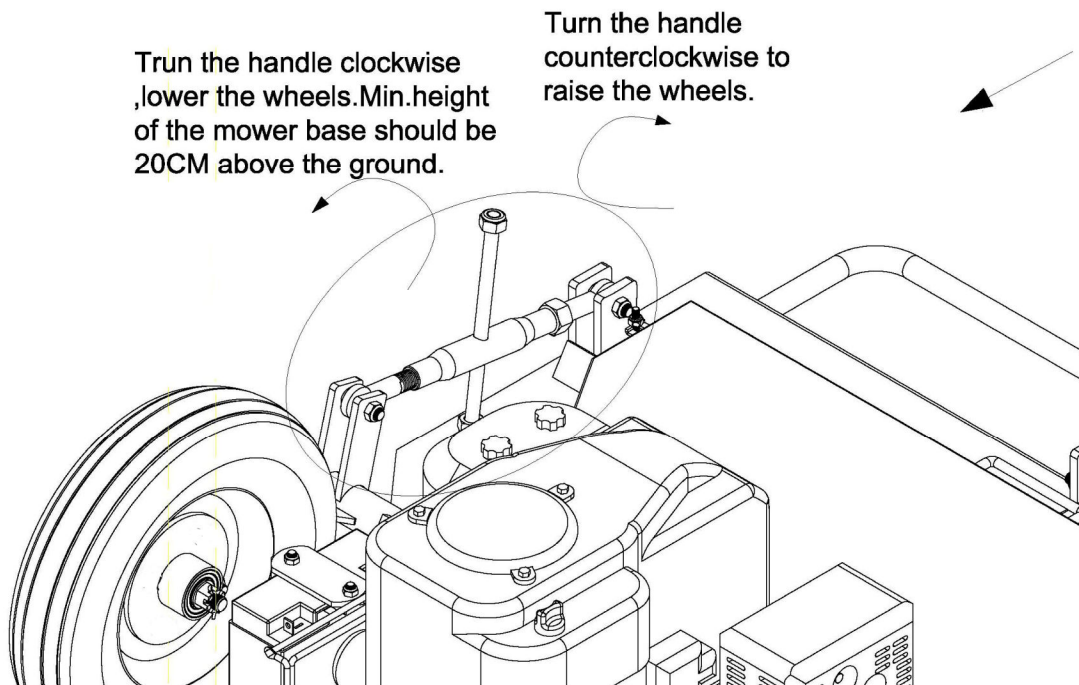

⚠ WARNING

Never adjust the height of the blades while the engine is running.

Blades will cut through skin and break bones. Keep hands and feet away from cutting blades and discharge areas.

Serious accidents can happen when other people are allowed inside the work area. Keep everyone else out of the work area while operating the mower.

Operation Instructions

Start the Engine

1. Make sure the tow vehicle park brake is set and the mower is level and the blades are set to the desired height.
2. Turn the fuel valve to the "ON" position.
3. Set the engine throttle to the "RUN" position.
4. Insert key into the engine switch and turn to "ON".

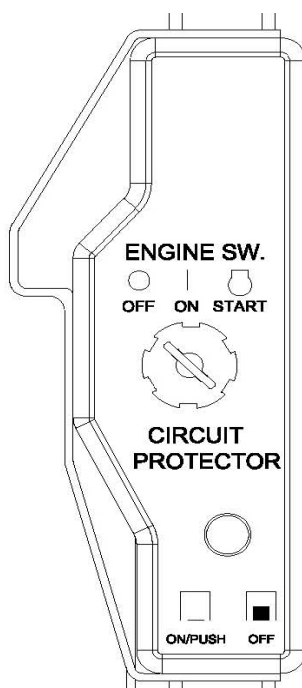

5. Start engine by turning key to "Start".
6. **Cold Engine Only** - Push the throttle lever down to operate the choke.
7. If motor does not start move the throttle lever to $\frac{1}{4}$ and try again.
8. Always set the throttle to full power for mowing/cutting.
9. Allow the engine to run for a few minutes before starting to use the mower.



CAUTION

The "ON" switch cannot be in START position for more than 5 seconds.
Always turn the fuel valve off once the engine is stopped.
Always ensure the ON/OFF switch is in the OFF position after using the mower.

Operation Instructions

Starting to Mow

1. Double check that the tow vehicle and mower are securely attached.
2. Always wear safety gear, eye & ear protection, gloves and work boots when operating.
3. Make sure the engine throttle is set at full throttle for best mowing/cutting performance.
4. Carefully mount vehicle and start mowing at a slow travel speed not to exceed 8 KPH.



CAUTION

Maximum mowing/cutting speed is 8 KPH.

Maximum towing/travel speed is 15 KPH (mower engine needs to be turned off).

Stop Mowing

1. Bring tow vehicle to a complete stop, shut off vehicle engine, turn fuel valve to the off position and set parking brake.
2. Shut mower engine off by manually turning toggle switch and/or key switch to the "OFF" position.
3. Turn mower engine fuel valve to the off position.
4. Always remember to remove keys to avoid irresponsible usage.

Transporting Mulch Mower

1. Make sure the engine is turn off.
2. Raise blades by turning the handle counterclockwise.
3. When transporting mower remove spark plug wire and put it in a place where it cannot have contact with the spark plug.

Note: 1. After working 10h, pls increase grease 15ml.



1. Every 8h of working, pls clean the glasses on blade.



Maintenance and Storage



WARNING

Improper maintenance and storage of the mower may void your warranty.

GENERAL MAINTENANCE

- Before performing maintenance, the mower engine must be turned off.
- After performing any maintenance, make sure all guards, shields and safety features are put back in place before operating the mower.
- Periodically check all fasteners for tightness.
- Grease pulley bearing assembly – Don't over grease 1 pump every 15-20 running hours.
- Annually clean and lightly lubricate all moving parts or when needed.
- Use a glossy enamel spray paint to touch up scratched or worn painted metal surfaces.
- Never use a high pressure wash or hose to clean the engine when it is running or hot.

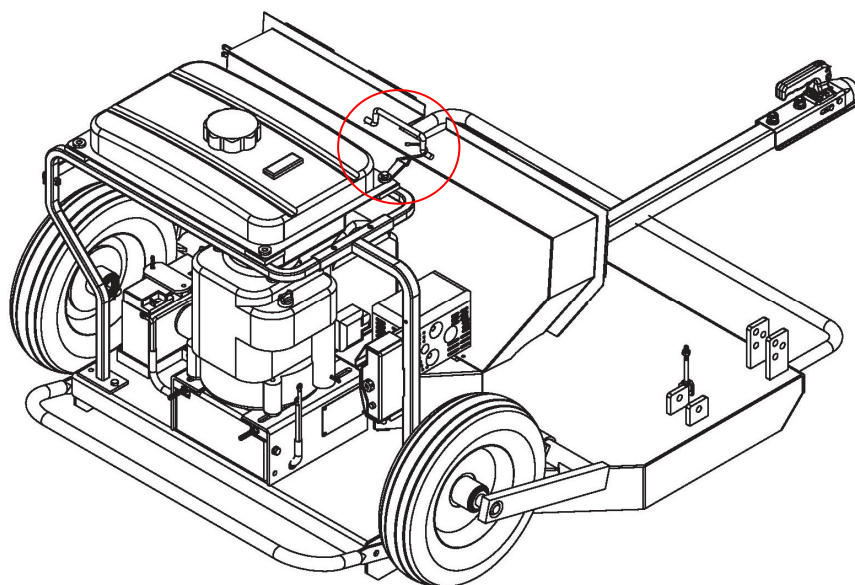

NOTE: MAKE THE HOOK ON THE HOOK OF HANDLE WHEN OPEN THE PROTECT COVER FOR SAFTY.

Engine & Cutter Belt Adjustment

1. The **ENGINE BELT** must be kept at the correct tension at all times.
 2. Loosen the engine mounting bolts and move the engine back until the belts are tight and then re-tighten the engine mounting bolts.
-
1. The **CUTTER BELT** has its own spring loaded pulley and does not require any adjustment.

NOTE: Belt Sizes – Engine / SPB686 and Cutter / SPB2180.

Cutter Blade Replacement

1. Refer to the BASE FRAME parts drawing & parts list.
2. Incline the mower to access the blades by lifting drawbar.
3. Put supports under the mower to avoid the mower falling and causing injury.
4. Remove the 2 bolts (#28), center bolts (#35) and cutting blade.
5. Reverse the procedure to install the blades.

Wheel Removal

1. Lower wheels completely by turning the blade handle clockwise.
2. Remove blade height control bolt on the turnbuckle (Engine end) and lift wheel axle.
3. Remove cotter pin and slide wheel off.

Refer to the Engine Owner's Manual for engine maintenance.

IMPORTANT:

If a part needs replacement, only use parts that meet the manufacturer's specifications. Replacement parts that do not meet specifications may result in a safety hazard or poor operations.

STORAGE

- Before storing make sure the mower is clean and dry for years of trouble free service.
- The engine and the fuel valve need to be in the off position.
- Lightly lubricate all mower surfaces and moving parts to prevent rust.
- Store indoors or protected area during severe weather and winter months.

Specifications

| | |
|--------------------------------|-----------------|
| Engine (Electric Start) | 16Hp |
| Shaft Output..... | Vertical |
| Engine RPM..... | 3600 |
| Battery | 12V DC/ 17AH |
| Fuel Capacity | 13L |
| Fuel Tank Size | 15L |
| Hitch Coupler | 50mm Cast Steel |
| Tire Size..... | 4.80/4.00-8 |
| Cutting Width | 117cm |
| Cutting Height | 25mm – 250mm |
| Max. Mowing/Cutting Speed..... | 8 KPH |
| Max. Towing/Travel Speed | 15 KPH |

NOTE: For Engine Details Refer to the Engine Owner's Manual.

Parts Drawing & Parts List

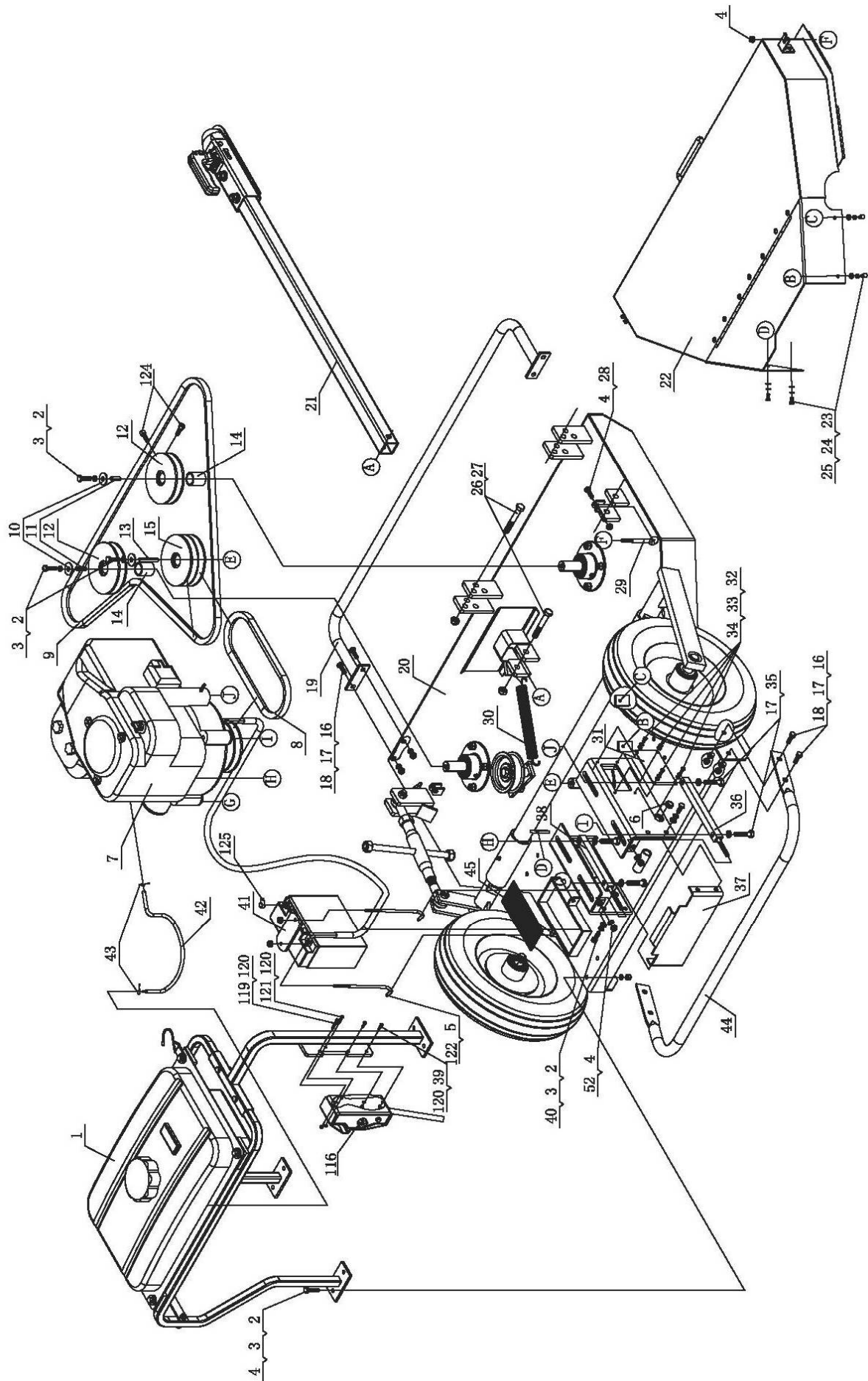

Parts Drawing & Parts List

| Ref# | Drawing No. | Description | Qty |
|------|------------------|------------------------|-----|
| 1 | NG01-10000 | Oil Tank Assembly | 1 |
| 2 | 9101-08025-DX8.8 | Hex Bolt M8x25 | 13 |
| 3 | 9306-08000-DX | Lock Washer Ø8 | 13 |
| 4 | 9206-08000-DX | Nylon Lock Nut M8 | 12 |
| 5 | NG01-00001-DX | Battery Hook | 2 |
| 6 | NG01-00002 | Rubber Bushing | 2 |
| 7 | NG01-20000 | Engine | 1 |
| 8 | NG01-00003 | SPB686 Engine Belt | 1 |
| 9 | NG01-00004 | SPB2180 Cutter Belt | 1 |
| 10 | NG01-00005-DX | Belt Pulley Washer A | 3 |
| 11 | NG01-00006 | Belt Pulley Flat Key A | 2 |
| 12 | NG01-00007-DX | Blade Belt Pulley A | 2 |
| 13 | NG01-00008 | Belt Pulley Flat Key B | 1 |
| 14 | NG01-00009-DX | Blade Retainer A | 2 |
| 15 | NG01-00010-DX | Blade Belt Pulley B | 1 |
| 16 | 9101-10025-DX8.8 | Hex Bolt M10x25 (8.8) | 8 |
| 17 | 9306-10000-DX | Lock Washer Ø10 | 12 |
| 18 | 9206-1000-DX | Nylon Lock Nut M10 | 8 |
| 19 | NG01-30000 | Safety Rod Front | 1 |
| 20 | NG01-40000 | Base Frame | 1 |
| 21 | NG04-01000 | Tow Bar Assembly | 1 |
| 22 | NG01-60000 | Protect Cover | 1 |
| 23 | 9101-06016-DX8.8 | Hex Bolt M6x16 (8.8) | 4 |
| 24 | 9306-06000-DX | Lock Washer Ø6 | 4 |
| 25 | 9301-06000-DX | Flat Washer Ø6 | 4 |
| 26 | 9101-12080-DX8.8 | Hex Bolt M12x80 (8.8) | 2 |
| 27 | 9206-12000-DX | Nylon Lock Nut M12 | 2 |
| 28 | 9101-08030-DX8.8 | Hex Bolt M8x30 (8.8) | 2 |
| 29 | NG01-00011-DX | Hook | 2 |
| 30 | NG01-00012 | Spring | 1 |
| 31 | NG01-00013 | Side Plate | 2 |
| 32 | 9101-05012-DX | Hex Bolt M5x12 | 8 |
| 33 | 9306-05000-DX | Lock Washer Ø5 | 8 |
| 34 | 9301-05000-DX | Flat Washer Ø5 | 8 |

Parts Drawing & Parts List

| Ref# | Drawing No. | Description | Qty |
|------|-------------------|--------------------------|-----|
| 35 | 9101-10045-DX8.8 | Hex Bolt M10x45 | 4 |
| 36 | NG01-70000 | Adjustable Plate B | 1 |
| 37 | NG01-80000 | Back Plate | 1 |
| 38 | BG01-90000 | Adjustable Plate A | 1 |
| 39 | 9101-05020-DX | Hex Bolt M5x20 | 2 |
| 40 | 9301-08000-DX | Flat Washer Ø8 | 2 |
| 41 | NG01-00014 | Battery Press Plate | 1 |
| 42 | NG01-00015 | Hydraulic Hose (350mm) | 1 |
| 43 | NG01-00016 | Hose Clamp | 2 |
| 44 | NG01-00017 | Safety Rod Back | 1 |
| 45 | NG01-00018 | Rubber Plate for Battery | 1 |
| 52 | 9302-08000-DX | Flat Washer Ø8 | 2 |
| 116 | NG01-24000 | Electric Start Switch | 1 |
| 119 | 9101-05035-DX | Hex Bolt M5x35 | 1 |
| 120 | 9206-05000-DX | Nylon lock Nut M5 | 4 |
| 121 | 9101-05025-DX | Hex Bolt M5x25 | 1 |
| 122 | 9206-06000-DX | Nylon lock Nut M6 | 2 |
| 124 | 9109-08025-FH12.9 | Screw M8x25 | 6 |
| 125 | NG01-00019-DX | Active Pulley Seal | 2 |
| 126 | LSP25-00009-DX | Axle Cap | 2 |

Parts Drawing & Parts List

FUEL TANK

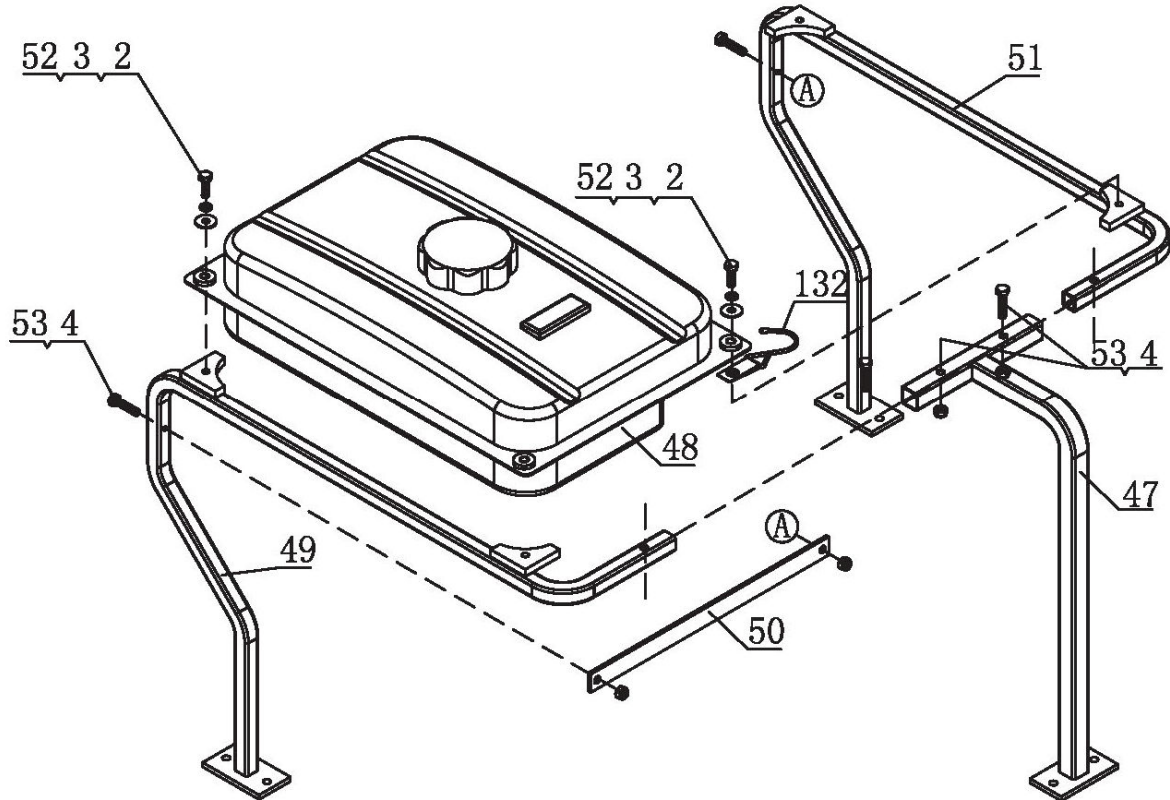

| Ref# | Drawing No. | Description | Qty |
|------|------------------|-------------------|-----|
| 2 | 9101-08025-DX8.8 | Hex Bolt M8x2.5 | 4 |
| 3 | 9306-08000-DX | Lock Washer Ø8 | 4 |
| 4 | 9206-08000-DX | Nylon Lock Nut M8 | 4 |
| 47 | NG01-12000 | Tube Assembly | 1 |
| 48 | NG01-13000 | Oil Tank Assembly | 1 |
| 49 | NG01-14000 | Engine Cradle B | 1 |
| 50 | NG01-10001 | Support Connector | 1 |
| 51 | NG01-11000 | Engine Cradle A | 1 |
| 52 | 9302-08000-DX | Big Washer Ø8 | 4 |
| 53 | 9101-08035-DX8.8 | Hex Bolt M8x35 | 4 |
| 132 | NG01-00023 | Hook | 1 |

Parts Drawing & Parts List

ENGINE

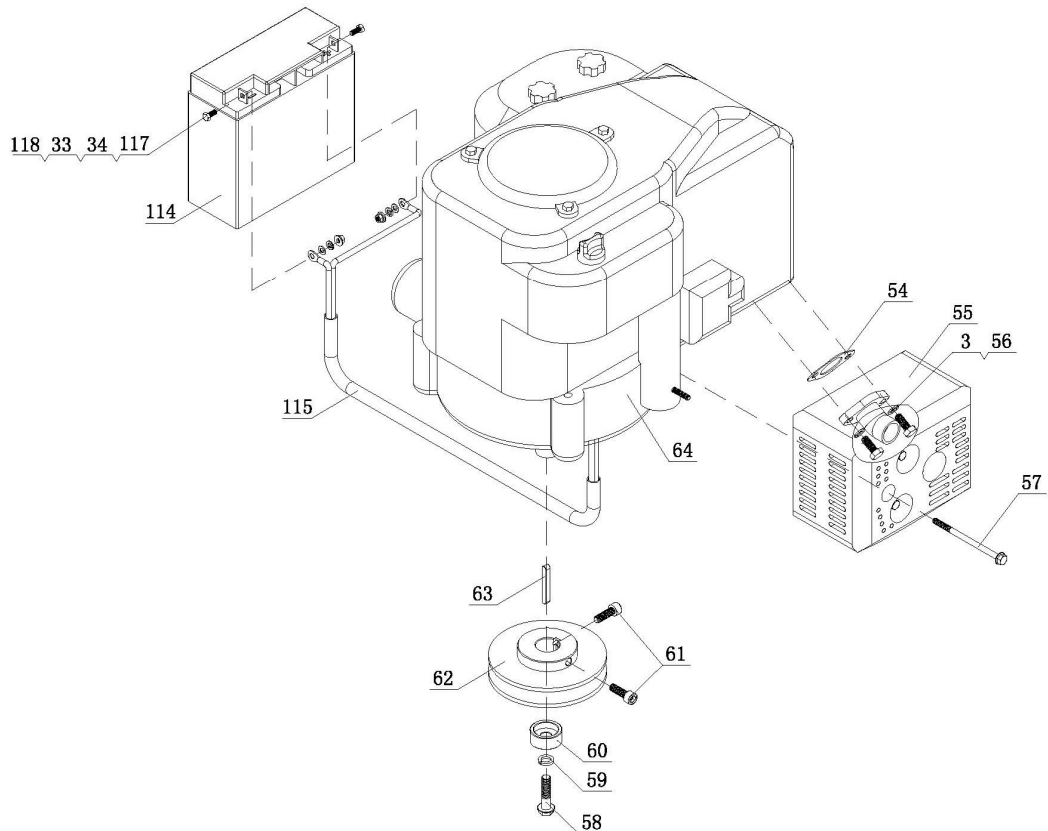

| Ref# | Drawing No. | Description | Qty |
|------|-------------------|------------------------|-----|
| 3 | 9306-08000-DX | Lock Washer Ø8 | 2 |
| 33 | 9306-05000-DX | Lock Washer Ø5 | 2 |
| 34 | 9307-05000-DX | Flat Washer Ø5 | 2 |
| 54 | NG01-20004 | Washer | 1 |
| 55 | NG01-22000 | Muffler | 1 |
| 56 | 9102-08025-DX8.8 | Hex Bolt 5/16"x1" | 2 |
| 57 | 9115-06120-DX10.9 | Flange Bolt M6x120 | 1 |
| 58 | 9115-11040-DX10.9 | Flange Bolt 7/16x40 | 1 |
| 59 | 9306-12000-DX | Lock Washer Ø12 | 1 |
| 60 | NG01-20001-DX | Engine Bushing | 1 |
| 61 | 9105-08025-DX8.8 | Inner Hex Screw M8x25 | 2 |
| 62 | NG01-20002-DX | Blade Belt Pulley C | 1 |
| 63 | NG01-20003 | Belt Pulley Flat Key C | 1 |
| 64 | NG01-21000 | Engine 16HP | 1 |
| 114 | NG01-20004 | 12V Battery | 1 |
| 115 | NG01-23000 | Wire | 1 |
| 117 | 9101-05016-DX | Hex Bolt M5x16 | 2 |
| 118 | 9212-05000-DX | Flange Nut M5 | 2 |

Parts Drawing & Parts List

BASE FRAME

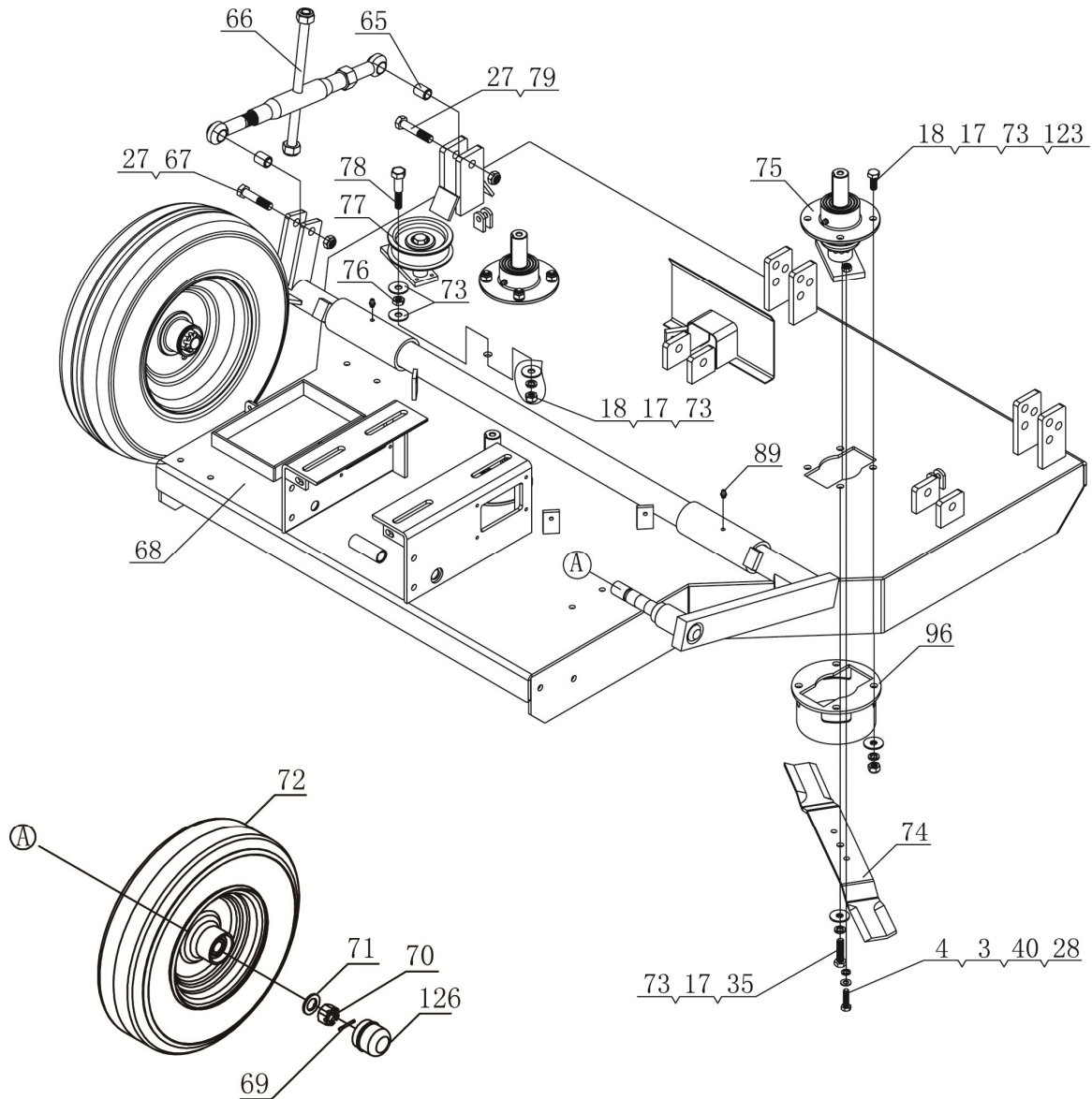

| Ref# | Drawing No. | Description | Qty |
|------|------------------|--------------------|-----|
| 3 | 9306-08000-DX | Lock Washer Ø8 | 6 |
| 4 | 9206-08000-DX | Nylon Lock Nut M8 | 6 |
| 17 | 9306-10000-DX | Lock Washer Ø10 | 16 |
| 18 | 9206-10000-DX | Nylon Lock Nut M10 | 13 |
| 27 | 9206-12000-DX | Nylon Lock Nut M12 | 2 |
| 28 | 9101-08030-DX8.8 | Hex Bolt M8x30 | 6 |
| 35 | 9101-10045-DX8.8 | Hex Bolt M10x45 | 3 |
| 40 | 9301-08000-DX | Flat Washer Ø8 | 6 |
| 65 | NG01-40001-DX | Bushing | 2 |
| 66 | NG01-41000 | Adjustable Handle | 1 |

Parts Drawing & Parts List

| Ref# | Drawing No. | Description | Qty |
|------|------------------|------------------------|-----|
| 67 | 9101-12055-DX8.8 | Hex Bolt M12x55 | 1 |
| 68 | NG01-45000 | Base Frame | 1 |
| 69 | 9404-04036-DX | Cotter Pin Ø4x36 | 2 |
| 70 | LSP25-00020-FH | Slotted Nut M20 | 2 |
| 71 | 9301-20000-DX | Flat Washer Ø20 | 2 |
| 72 | LSP25-14000 | Wheel | 2 |
| 73 | 9302-10000-DX | Big Flat Washer Ø10 | 18 |
| 74 | NG01-40002 | Blade | 3 |
| 75 | NG01-44000 | Blade Base | 3 |
| 76 | 9201-10000-DX | Hex Nut M10 | 1 |
| 77 | NG01-42000 | Tension Pulley | 1 |
| 78 | NG01-40003-DX | Connect Bolt | 1 |
| 79 | 9101-12060-DX8.8 | Hex Bolt M12x60 | 1 |
| 89 | 9701-06000 | Oil Cup M6 | 2 |
| 96 | NG01-9100 | Large Guardrail Circle | 3 |
| 123 | 9102-10030-DX8.8 | Hex Bolt M10x30 | 12 |
| 126 | LSP25-00009-DX | Axle End Cap | 2 |

Parts Drawing & Parts List

TOW BAR

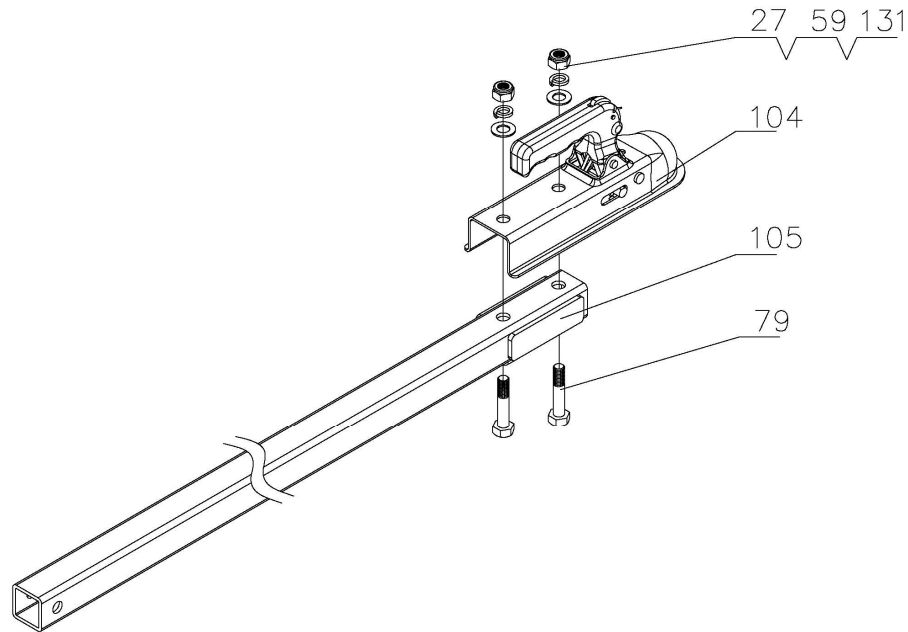

| Ref# | Drawing No. | Description | Qty |
|------|------------------|--------------------|-----|
| 27 | 9206-12000-DX | Nylon Lock Nut M12 | 2 |
| 59 | 9306-12000-DX | Lock Washer Ø12 | 2 |
| 79 | 9101-12060-DX8.8 | Hex Bolt M12x60 | 2 |
| 104 | Z104SP | 50mm Coupler | 1 |
| 105 | NG04-01000 | Tow Bar | 1 |
| 131 | 9301-12000-DX | Flat Washer Ø12 | 2 |

Parts Drawing & Parts List

PROTECT COVER

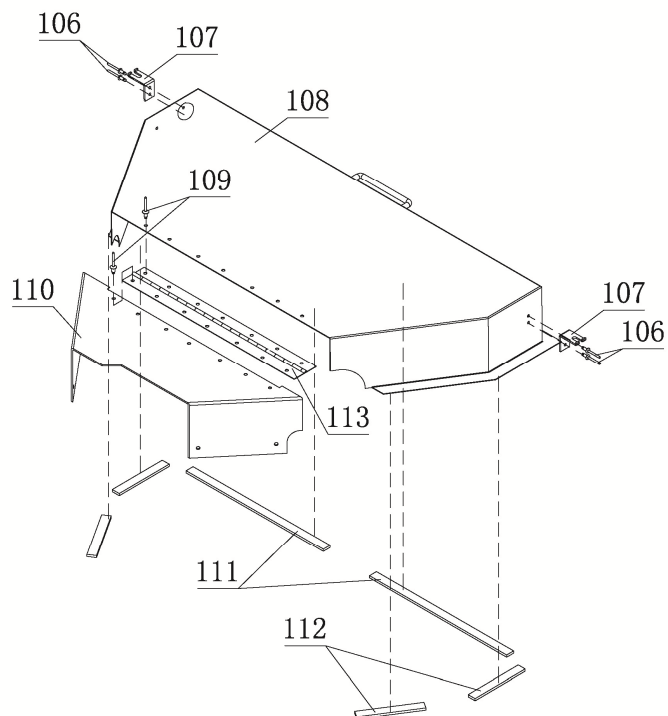

| Ref# | Drawing No. | Description | Qty |
|------|---------------|-------------------|-----|
| 106 | 9504-05012-YH | Rivet Ø5x12 | 4 |
| 107 | NG01-60001-DX | Turn Clip | 2 |
| 108 | NG01-61000 | Protect Cover | 1 |
| 109 | 9504-06012-YH | Rivet Ø16x12 | 14 |
| 110 | NG01-60004 | Belt Pulley Cover | 1 |
| 111 | NG01-60002 | Shock Pad Long | 2 |
| 112 | NG01-60003 | Shock Pad Short | 4 |
| 113 | NG01-62000-DX | Hinge | 1 |

Parts Drawing & Parts List

ADJUSTABLE BLADE HANDLE

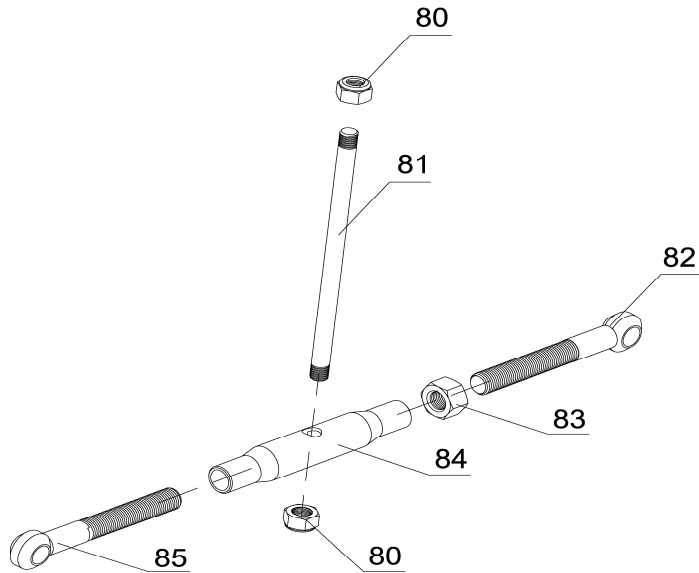

| Ref# | Drawing No. | Description | Qty |
|------|---------------|-------------------------|-----|
| 80 | 9206-14000-DX | Nylon Lock Nut M14 | 2 |
| 81 | NG01-41001-DX | Adjustable Handle | 1 |
| 82 | N630-50002-DX | Adjustable Rod A | 1 |
| 83 | 9201-20000-DX | Hex Nut M20 | 1 |
| 84 | NG01-41002-DX | Adjustable Rod (middle) | 1 |
| 85 | N630-50001-DX | Adjustable Rod B | 1 |

Parts Drawing & Parts List

TENSION BELT PULLEY

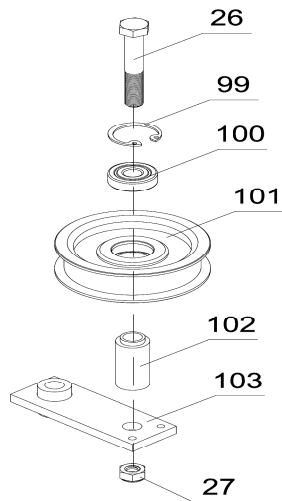

| Ref# | Drawing No. | Description | Qty |
|------|------------------|-----------------------------|-----|
| 26 | 9101-12080-DX8.8 | Hex Bolt M12x80 | 1 |
| 27 | 9206-12000-DX | Nylon Lock Nut M12 | 1 |
| 99 | 9309-32000-FH | Spring Retainer A Ø32 | 1 |
| 100 | 9602-32010 | 6201 Deep Hook Ball Bearing | 1 |
| 101 | NG01-42001-DX | Tension Pulley | 1 |
| 102 | NG01-42002-DX | Support Rod A | 1 |
| 103 | NG01-42100-DX | Support Rod B | 1 |

Parts Drawing & Parts List

BLADE BASE

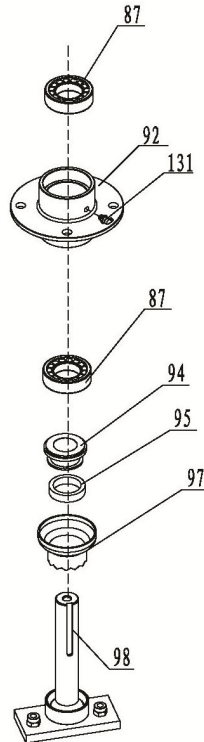

| Ref# | Drawing No. | Description | Qty |
|------|---------------|---------------------|-----|
| 87 | 9603-6205 | Roller Bearing | 2 |
| 92 | NG01-44001-DX | Flange Base | 1 |
| 94 | NG02-02002-DX | Bearing Retainer | 1 |
| 95 | NG02-02003 | Felt Ø30xØ39 | 1 |
| 97 | NG01-44003-DX | Dust Cover | 1 |
| 98 | NG01-44100-DX | Blade Base | 1 |
| 131 | 9701-06000 | Elbow Grease Cup M6 | 1 |



1P88F-1

1P90F-1

1P92F-1

Owner's Manual



TABLE OF CONTENTS

| | |
|----------------------------------|---|
| 1. General information | 1 |
| 2. Safety regulations | 1 |
| 3. Components and controls | 2 |
| 4. What you need to know | 3 |
| 5. Standards of use | 4 |
| 6. Maintenance | 6 |
| 7. Troubleshooting | 8 |
| 8. Technical data | 8 |

1. GENERAL INFORMATION

1.1 READING AND UNDERSTANDING THE MANUAL

Some paragraphs in the manual containing information of particular importance for safety and operation are highlighted at various levels of emphasis, and signify the following:

NOTE

or

IMPORTANT

These give details or further information on what has already been said, and aim to prevent damage either to the engine or other damages.

▲ WARNING! *Non-observance will result in the risk of injury to oneself or others.*

▲ DANGER! *Non-observance will result in the risk of serious injury or death to oneself or others.*

NOTE

All indications, "front", "rear", "right" and "left", are to be taken as referring to the engine positioned with the spark plug facing forwards with respect to the observer.

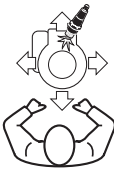

The number before the paragraph title refers to the text references and their related figures (shown inside front and back covers).

1.2 SAFETY SYMBOLS

Your engine should be used with due care and attention. Symbols have therefore been placed on the engine to remind you of the main precautions to be taken. Their full meaning is explained later on.

You are also asked to carefully read the safety regulations in the applicable chapter of this handbook.



Warning! - Read and follow Operating Instructions before running engine.



Warning! - Gasoline is flammable. Allow engine to cool at least 2 minutes before refuelling.



Warning! - Engines emit carbon monoxide. DO NOT run in enclosed area.

2. GENERAL SAFETY STANDARDS

(to be strictly applied)

A) TRAINING

- 1) Carefully read the instructions contained in this manual and the instructions of the machine on which this engine is installed. Learn how to stop the engine quickly.
- 2) Never allow people unfamiliar with these instructions to use the engine.
- 3) Never use the engine while people, especially children, or pets are nearby.
- 4) Remember that the operator or user is

responsible for accidents or hazards occurring to other people or their property.

B) PREPARATION

- 1) Do not wear loose-fitting clothing, dangling drawstrings, jewels or items that could become caught; tie up long hair and keep at safe distance while starting the lawnmower.
- 2) Turn engine OFF and let it cool before removing gas cap.
- 3) **WARNING: DANGER!** Fuel is highly flammable:
 - store the fuel in special containers;
 - refuel only outdoors by using a funnel; never smoke while refueling and/or handling fuel;

- *add fuel before starting the engine. Never remove the cap of the fuel tank or add fuel while the engine is running or when the engine is hot;*
 - *if you have spilt some fuel, do not attempt to start the engine but move the machine away from the area of spillage and avoid creating any source of ignition until the fuel has evaporated and fuel vapours have dissipated.*
 - *always put the tank and fuel container caps back on and tighten well.*
- 4) *Replace faulty silencers and the guard, if damaged.*

C) OPERATION

- 1) *Do not operate the engine in a confined space where dangerous carbon monoxide fumes can collect.*
- 2) *Do not use starting fluids or similar products.*
- 3) *Do not change the engine governor settings or overspeed the engine.*
- 4) *Do not tilt the machine onto its side to prevent fuel leaks from the fuel tank cap.*
- 5) *Do not touch the cylinder fins and/or the silencer guard until the engine has cooled down.*
- 6) *Stop the engine and disconnect the spark plug cable before checking, cleaning or servicing the machine or the engine.*
- 7) *Do not crank the engine with spark plug removed.*
- 8) *Transport the machine with empty tank.*

D) MAINTENANCE AND STORAGE

- 1) *A routine maintenance is essential for safety and for keeping a high performance level.*
- 2) *Do not store the machine with fuel in the tank in an area where the fuel vapours could reach an open flame, a spark or a strong heat source.*
- 3) *Allow the engine to cool before storing in any enclosure.*
- 4) *To reduce the fire hazard, keep the engine, the silencer and the fuel storage area free of grass, leaves, or excessive grease.*
- 5) *If the fuel tank has to be drained, this should be done outdoors once the engine has cooled down.*
- 6) *For safe operation, never use the engine with either worn or damaged parts. Parts are to be replaced and not repaired. Use genuine spare parts. Parts that are not of the same quality can damage the engine and impair your safety.*

3. COMPONENTS AND CONTROLS

3.1 ENGINE COMPONENTS

1. Oil filler cap with dipstick
2. Oil drain plug
3. Air cleaner cover
4. Fuel stopcock
5. Spark plug cap
6. Engine code



| | | | | | | | | | | | | | | | | | | | |
|--|--|--|--|--|--|--|--|--|--|--|--|--|--|--|--|--|--|--|--|
| | | | | | | | | | | | | | | | | | | | |
|--|--|--|--|--|--|--|--|--|--|--|--|--|--|--|--|--|--|--|--|

Note your engine serial number here

3.2 ACCELERATOR CONTROL

The throttle trigger (generally a lever), fitted to the machine, is connected to the engine by a cable.

Consult the machine's Instructions Manual to identify the throttle trigger and its positions, usually marked by symbols, corresponding to:



CHOKE = to be used for starting from cold.



FAST = corresponds to maximum revs; to be used when working.



SLOW = corresponds to minimum revs.

4. WHAT YOU NEED TO KNOW

The engine performance, reliability and life are influenced by many factors, some external and some strictly associated with the quality of the products used and with the scheduled maintenance.

The following information allow a better understanding and use of your engine.

4.1 ENVIRONMENTAL CONDITIONS

The operation of a four-stroke endothermic engine is affected by:

a) Temperature:

- Working in low temperatures could lead to a difficult cold starting.
- Working in very high temperatures could lead to a difficult hot starting due to the evaporation of the fuel either in the carburetor float chamber or in the pump.
- In any case, the right kind of oil must be used, according to the operating temperatures.

b) Altitude:

- The higher the altitude (above sea level), the lower the max power developed by an endothermic engine.
- When there is a considerable increase in altitude, the load on the machine should be reduced and particularly heavy work avoided.

4.2 FUEL

A good quality fuel is important for reliable engine operation.

- a) Use unleaded gasoline, with a minimum of 90 octane.
- b) Use clean, fresh fuel; purchase fuel in quantity that can be used within 30 days, to prevent gum from forming inside the container or the tank.
- c) Do not use fuel which contains Methanol.
- d) Do not add neither oil nor any kind of fuel additive.

4.3 OIL

Use always high quality oils, choosing their viscosity grade according to the operating temperature.

- a) Use only detergent oil classified SF-SG.
- b) Choose the SAE viscosity grade of oil from this chart:
 - from 5 to 35 °C = SAE 30
 - from -15 to + 5 °C = 5W-30 or 10W-30 (Multi-viscosity)
 - from -25 to + 35 °C = Synthetic oils 5W-30 or 10W-30 (Multi-viscosity)
- c) The use of multi-viscosity oils in hot temperatures will result in higher than normal oil consumption; therefore, check oil level more frequently.
- d) Do not mix oils of different brands and features.
- e) SAE 30 oil, if used below 5°C, could result in possible engine damage due to inadequate lubrication.
- f) Oil should be at "MAX" mark, do not overfill. Overfilling with oil may cause:
 - Smoking;
 - Spark plug or air filter fouling, which will cause hard starting.

4.4 AIR FILTER

The air filter must always be in perfect working order, to prevent debris and dust from getting sucked into the engine, reducing the efficiency and life of the machine.

- a) Always keep the filtering element free of debris and in perfect working order.
- b) If necessary, replace the filtering element with an original spare part. Incompatible filtering elements can impair the efficiency and life of the engine.
- c) Never start the engine without mounting the filtering element properly.

4.5 SPARK PLUG

Not all the spark plugs for endothermic engines are the same!

- a) Use only spark plugs of the recommended type, with the right heat range.
- b) Check the length of the thread, because - if too long - it will damage the engine beyond repair.
- c) Make sure that the electrodes are clean and their gap is correct.

5. STANDARDS OF USE

5.1 BEFORE EVERY USE

Before every use, perform the following checking procedures in order to assure a regular operation.

5.1.1 Check oil level

See the specific chapter (8.1) for the oil to be used.

- a) Place engine level.
- b) Clean around oil fill.
- c) Unscrew the cap, clean the end of the dipstick and insert it, as illustrated, without screwing it down.
- d) Remove the cap with the dipstick and check the oil level that must be between the "MIN" and "MAX" marks.
- e) If oil is required, add oil of the same kind up to the "MAX" mark, being careful not to spill any outside the oil fill.
- f) Fully tighten the filler cap and wipe off any spilled oil.

5.1.2 Check air cleaner

The efficiency of the air filter is fundamental for the engine to work properly. Do not start the engine if the filtering element is missing or broken.

- a) Clean around the filter cover.
- b) Remove the cover by unscrewing the two knobs.
- c) Check the condition of the filtering element. It must be intact, clean and in perfect working order; if not, either carry out maintenance or replace it.
- d) Put the cover back.

5.1.3 Adding fuel

IMPORTANT

Do not drip petrol onto the plastic parts of the motor or the machine to prevent damaging them and remove all traces of spilt petrol immediately. The warranty does not cover damage to plastic parts caused by petrol.

See "Technical Data" chapter (8.1) for the fuel characteristics.

Refuelling must be made when the engine is cold, following the instructions contained in the machine's Instructions Manual.

5.1.4 Spark plug cap

Firmly connect the cable cap to the spark plug, making sure that there are no traces of dirt inside the cap and on the spark plug terminal.

5.2 STARTING THE ENGINE (cold)

The engine must be started in the way described in the machine's Instruction Manual, always making sure that any device (if present) that could cause the machine to advance or the engine to stop is disengaged.

- a) Open the fuel stopcock.
- b) Move the throttle to "CHOKE".
- c) Turn the starter key as described in the machine's instruction manual.

After a few seconds, slowly move the throttle from "CHOKE" to either "FAST" or "SLOW".

NOTE

If the engine starts but does not keep running, repeat the above steps with the throttle on "FAST".

5.3 STARTING THE ENGINE (hot starting)

- Follow the whole cold-starting procedure with throttle control in "FAST" position.

5.4 USE OF THE ENGINE IN OPERATION

Maximum revs must be used to optimise the engine's yield and performance, by setting the throttle trigger to "FAST".

▲ WARNING!

Keep your hands away from the silencer and surrounding areas that can become extremely hot. With the engine running, do not get loose-fitting clothing (ties, scarves, etc.) or hair closer to the top part of the engine.

IMPORTANT *Do not operate on over 20° inclines to prevent malfunctioning of the engine.*

5.5 STOPPING THE ENGINE DURING MOWING

- a) Move the throttle to "SLOW".
- b) Allow the engine to run at minimum speed for at least 15-20 seconds.
- c) Stop the engine following the instructions contained in the machine's Instructions Manual.

5.6 STOPPING THE ENGINE AFTER MOWING

- a) Move the throttle to "SLOW".
- b) Allow the engine to run at minimum speed for at least 15-20 seconds.
- c) Stop the engine following the instructions contained in the machine's Instructions Manual.
- d) When the engine is cold, disconnect the spark plug and remove the starter key (if present).
- e) Close the fuel stopcock.
- f) Remove any debris from the engine and especially around the exhaust silencer to reduce the risk of fire.

5.7 CLEANING AND STORAGE

- a) Do not spray with water or use hydraulic lances to clean the exterior of the engine.
- b) Use a compressed air gun (max. 6 bars) for preference, thus preventing debris and dust from penetrating inside.
- c) Store the lawnmower (and the engine) in a dry place, sheltered from severe weather conditions and sufficiently ventilated.

5.8 LONG STORAGE (over 30 days)

In case the engine has to be stored for a long time (for example at the end of the season), a few precautions are needed to help the future start-up.

- a) To prevent the formation of deposits inside the tank, empty it of fuel by unscrewing the carburettor float chamber plug and collect-

ing all the fuel in a suitable container. At the end of the operation remember to screw the plug back on and fully tighten it.

- b) Remove the spark plug and pour about 3 cl of clean engine oil into the spark plug hole, then, having blocked the hole with a rag, run the starter motor briefly to turn the engine for a few revs and distribute the oil over the inner surface of the cylinder. Finally replace the spark plug without connecting the cable cap.

6. MAINTENANCE

6.1 SAFETY RECOMMENDATIONS

⚠ WARNING! Remove the spark plug cap and read instructions before carrying out any cleaning, repair or maintenance operation. Wear proper clothing and working gloves whenever your hands are at risk. Do not perform maintenance or repair operations without the necessary tools and technical knowledge.

IMPORTANT Never get rid of used oil, fuel or other pollutants in unauthorised places.

6.2 MAINTENANCE SCHEDULE

Follow the hourly or calendar – whichever occur first – maintenance schedule shown in the following table.

| Operation | After First 5 hours | Every 5 hours or daily | Every 50 hours or every season | Every 100 hours |
|---|---------------------|------------------------|--------------------------------|-----------------|
| Check oil level | - | ✓ | - | - |
| Change oil ¹⁾ | ✓ | - | - | ✓ |
| Clean silencer and engine | - | ✓ | - | - |
| Air filter cleaning ²⁾ and check | - | ✓ | - | - |
| Air filter replacement ²⁾ | - | - | ✓ | - |
| Check spark plug | - | - | ✓ | - |
| Replace spark plug | - | - | - | ✓ |
| Fuel filter check ³⁾ | - | - | - | ✓ |

¹⁾ Change oil every 25 hours if the engine is operating under heavy load or in hot weather.

²⁾ Clean air cleaner more frequently if the machine is operating in dusty areas.

³⁾ To be carried out by a specialized Centre.

6.3 CHANGE OIL

See the specific chapter (8.1) for the oil to be used.

⚠ WARNING! Drain oil while the engine is warm, being careful not to touch the hot engine nor the drained oil.

- Place the machine on a flat surface.
- Clean the area around the filler cap and unscrew the cap with dipstick.
- Provide a suitable container for collecting the oil and unscrew the drain plug.
- Refit the drain plug and fully tighten it having made sure that the gasket is in the right position.
- Fill up with fresh oil.
- Check that the oil level has reached the "MAX" notch on the dipstick.
- Close the cap again and clean up any traces of oil that was possibly spilt.

NOTE

The oil capacity is about 1.2 liter.

⚠ WARNING!

• The length of time that gasoline can be left in your fuel tank and carburetor without causing functional problems will vary with such factors as gasoline blend, your storage temperatures, and whether the fuel tank is partially or completely filled. The air in a partially filled fuel tank promotes fuel deterioration. Very warm storage temperatures accelerate fuel deterioration. Gasoline will oxidize and deteriorate in storage. Deteriorated gasoline will cause hard starting, and it leaves gum deposits that clog the fuel system. As a result, if the engine is not used for more than one month, the fuel oil shall be drained thoroughly to prevent from deterioration of the fuel in fuel system and carburetor.

• The failures of fuel system or engine performance arising from improper storage are beyond the scope of the warranty.

6.4 CLEAN SILENCER AND ENGINE

Silencer must be cleaned when the engine is cold.

- a) Use a jet of compressed air to remove any debris and dirt that could cause a fire from the silencer and its protective cover.
- b) Make sure that the cooling air intakes are not blocked.
- c) Clean the plastic components with a sponge soaked in water and detergent.

6.5 AIR FILTER MAINTENANCE

- a) Clean the area around the filter cover.
- b) Remove the cover by unscrewing the two knobs.
- c) Remove the filtering element.
- d) Tap the cartridge on a solid surface and blow it from the inside with compressed air to remove dust and debris.

IMPORTANT *Do not use water, petrol, detergents or any other products to clean the cartridge.*

IMPORTANT *The sponge pre-filter must NEVER be oiled.*

- e) Clean the inside of the filter housing from dust and debris, making sure to block the inlet duct with a rag to prevent them from entering the engine.
- f) Remove the rag, install the filtering element in its housing and refit the cover.

6.6 SPARK PLUG SERVICE

- a) Remove the spark plug using a spark plug socket wrench.
- b) Clean the electrodes with a metal brush and remove any carbonaceous build-up.
- c) Using a thickness gauge, check for the right gap (0.6-0.8mm) between the electrodes.
- d) Install the spark plug and tighten with a socket wrench.

Replace the spark plug if the electrodes are burnt or if the porcelain is broken or damaged.

⚠ WARNING! *Fire hazard! Do not check the ignition system with spark plug removed.*

IMPORTANT *Use only spark plugs of the recommended type.*

6.7 TUNING THE THROTTLE CABLE AND THE CARBURETTOR

Should the engine not reach maximum revs with the throttle trigger set to "FAST", it could be due to the throttle trigger and speed control lever being out of phase or to a carburetion problem.

Go to a specialised Centre or contact your Dealer to restore normal operation.

6.8 CARBURETOR MODIFICATION FOR HIGH ALTITUDE OPERATION

At high altitude, the standard carburetor air-fuel mixture will be too rich. Performance will decrease, and fuel consumption will increase. A very rich mixture will also foul the spark plug and cause hard starting. Operation at an altitude that differs from that at which this engine was certified, for extended periods of time, may increase emissions.

High altitude performance can be improved by specific modifications to the carburetor. If you always operate your engine at altitudes above 5,000 feet (1,500 meters), have your servicing dealer perform this carburetor modification. This engine, when operated at high altitude with the carburetor modifications for high altitude use, will meet each emission standard throughout its useful life.

7. TROUBLESHOOTING

| PROBLEM | LIKELY CAUSE | SOLUTION |
|-----------------------------------|---|---|
| a) Hard starting | - No fuel | - Check and top up |
| | - Stale fuel or build-ups in tank | - Empty fuel tank and refill with fresh fuel |
| | - Incorrect starting procedure | - Perform the starting procedure correctly |
| | - Spark plug disconnected | - Check that the spark plug cap fits well over the plug terminals |
| | - The spark plug is wet or the spark plug electrodes are dirty or placed inadequately | - Check |
| | - Air filter clogged | - Check and clean |
| | - Incorrect oil for the season | - Replace with proper oil |
| | - Fuel evaporation in the carburetor (vapor lock) due to high temperatures | - Wait for a few minutes then start again |
| | - Fault in carburation | - Contact a Licensed Service Centre |
| | - Hard starting | - Contact a Licensed Service Centre |
| b) Inconsistent working | - Dirty electrodes or incorrect gap | - Check |
| | - The spark plug cap is inserted incorrectly | - Check that the cap is fitted correctly |
| | - Air filter clogged | - Check and clean |
| | - Throttle trigger in "CHOKE" position | - Move the lever to the "FAST" position |
| | - Fault in carburation | - Contact a Licensed Service Centre |
| | - Fault in ignition | - Contact a Licensed Service Centre |
| c) Loss of power whilst operating | - Air filter clogged | - Check and clean |
| | - Fault in carburation | - Contact a Licensed Service Centre |
| | - Governor out of phase with respect to the accelerator | - Adjust the cable |

8. TECHNICAL SPECIFICATIONS

8.1 REFILLING AND OPERATION MATERIALS

| | |
|----------------------------------|--------------------------------------|
| Fuel | Unleaded gasoline, minimum 90 octane |
| Engine oil: from 5 to 35 °C..... | SAE 30 |
| from -15 to +5 °C..... | 5W-30 or 10W-30 |
| from -25 to +35 °C..... | Synthetic 5W-30 or 10W-30 |
| Oil capacity | 1.2 liter |
| Spark plug | RC12YC(Champion) or equivalent |
| Spark plug gap | 0.6 - 0.8 mm |

Engine wiring diagram

